

Installation Instruction

Sierra Auxiliary I/O Harness

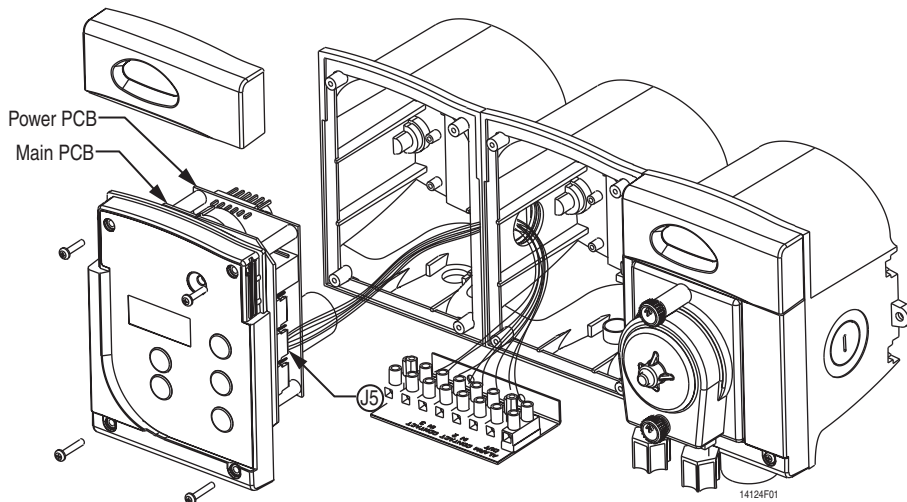

1. Remove top sliding covers of controller and second box by inserting a small screwdriver under the right side of cover. Gently pry off, taking care not to damage the unit.
2. Remove all 8X screws that attach cover of Controller and second box.
3. Adhere standoffs (2X) to inside of second box as shown.
4. Snap harness bracket into place over standoffs with terminal block facing up.
5. Remove cover of Controller, pulling it out far enough to access the connectors along the right side of the PCB.
6. Route harness wires and connector through side hole and connect to J5 on Main PCB.
7. Close Controller cover and reinstall screws and top sliding cover.
8. Make appropriate wiring connections to auxiliary I/O terminal block using bottom or side knockouts as holes.
9. Close cover of second box, reinstalling screws and sliding cover.

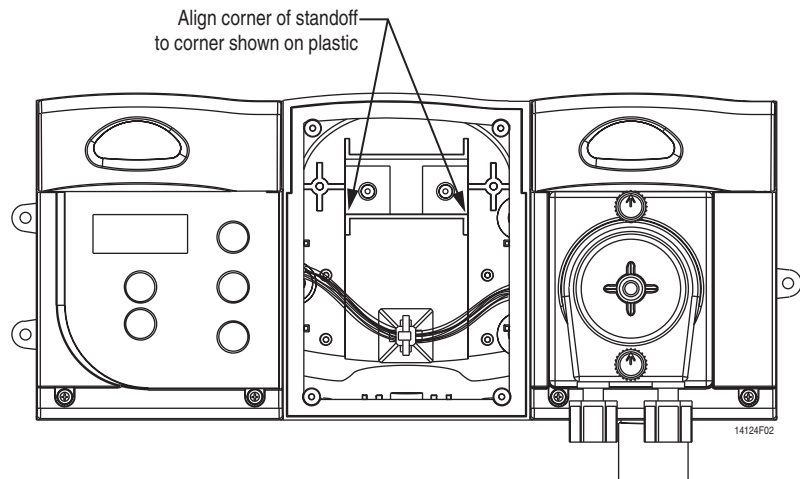

TEL • 831 • 426 • 0882
TEL • 800 • 858 • 2382
FAX • 831 • 423 • 4573
FAX • 800 • 221 • 8916

Customer Service

TEL • 800 • 215 • 6415 Tech Support
sales@beta-technology.com



Freephone • 0800 • 052 • 4726
Tel • +44(0) • 1582 • 528600
Fax • +44(0) • 1582 • 528111
Freephone • 0800 • 052 • 4726 Tech Service
VAT REG. NO. BG.354 - 09975 - 44
europe.sales@beta-technology.com

Online Ordering: <http://www.beta-technology.com>